

Monitoring System of the Parameters of Operation of internal Combustion Engines in Thermoelectric Plants for Fault Detection.

Paulo Francisco da Silva Ribeiro¹, Manoel Henrique Reis Nascimento², Jorge de Almeida Brito Junior³, Jandecy Cabral Leite⁴, Carlos Alberto Oliveira de Freitas⁵

¹Research Department, Institute of Technology and Education Galileo of the Amazon (ITEGAM)

Email: paulo.ribeiro@itegam.org.br

²Research Department, Institute of Technology and Education Galileo of the Amazon (ITEGAM)

Email: hreys@itegam.com.br

³Research Department, Institute of Technology and Education Galileo of the Amazon (ITEGAM)

Email: Jorge.brito@itegam.com.br

⁴Research Department, Institute of Technology and Education Galileo of the Amazon (ITEGAM)

Email: Jandecy.cabral@itegam.com.br

⁵Research Department, Institute of Technology and Education Galileo of the Amazon (ITEGAM)

Email: carlos.freitas@itegam.com.br

Abstract—In this work, it shows the specification of a system for monitoring operating parameters of generators, for diagnostic and fault detection on power generation of thermal power plants (TPP). The objective of this system is to collect real-time information of the engine operating cycle dual-fuel, while working with diesel and natural gas, in order to organize a database with the pressure information from the combustion temperature and cooling water pressure. The use of local or remote monitoring is performed by sensors to detect variations or sudden changes in the generator mode. Through this real-time monitoring can be identified early failures, adapt to changes or repairs parts preserving the integrity of the machines.

Keywords—Sensors, operation of generators, fault detection, TPP.

I. INTRODUCTION

The Domestic Energy Supply - OIE in 2016 stood at 288.3 million Tons of Oil Equivalent (TOE), or (MTEP), showing a decrease of 3.8% compared to 2015, equivalent to 2.07% the world's energy. The significant fall OIE, consistent with the decrease of 3.6% in the economy was mainly inducing a reduction of almost 20% in transformation losses due to the lower thermal generation and the reduction of 5.3% in the sector consumption energy (decrease of 7% in ethanol). The total demand for petroleum products fell by 5.6% (-7.2% in 2015), there including end uses in the sectors of the economy and the uses in the generation of electricity. The consumption in light vehicles decreased by 1.6% (an increase of 6.2% in

2014 and 2015 in stable (MME 2016). Generation of Electric Energy (EE) is increasing in developing countries due to the massive consumption of EE, although in Brazil the main source of EE be Hydraulic generation with 66% of total generation (Trinity, Sperling & Bourbon, 2017). Still have a significant percentage coming from non-renewable energy sources accounting for 18%, in northern Brazil 18.2% of the total energy are Thermoelectric (EPE 2017). In the industrialized world Brazil has the energy matrix with the highest share of renewable sources to 43.5% of its production comes from hydropower, biomass and ethanol, including solar and wind power, pointing out that the non-renewable oil and its derivatives is the highest percentage 36.5%, reflecting the dependence of fossil fuels in Brazil (MME 2016). In Brazil, it uses the thermal energy in a strategic way, as it can be produced in a constant amount throughout the year, unlike hydropower, which have the dependent production level of rivers (Lima & Souza, 2014).

For generating thermal energy is used, a set of Internal Combustion Engines and Generators (ICEG), which sometimes occur untimely interruptions due to internal set of problems, which can cause major losses to the dealership. A careful evaluation of the operating conditions of these motors, can lead to a substantial increase in its reliability and an effective program of asset management (Mendonca et al., 2007). Failures and outages can result in high costs and severe fines. Because of this high cost, predictive maintenance based on the ICEG's runs parameters, is earning more and more importance in preventing failure of these engines. Rapid

detection and identification of faults that affect a process can help make decisions, correct and reduce the damage that can cause the system (Cabeza Santiago Vicedo, & Vega, 2018).

The use of local or remote monitoring is performed by sensors to detect variations or sudden changes in the generator mode. Through this real-time monitoring can be identified early failures, adapt to changes or repairs parts preserving the integrity of the machines.

The smooth operation of these machines, represents a strategic advantage for the electric power generation systems, especially in developing countries. Different technologies for fault detection in ICEG's have been implemented, such as: Martinez uses a model-based approach with a multi-variable generation of waste from the main fault situations, arranged in a matrix characteristic of fault signatures, establishing a standard reference to continuously evaluate waste in on-line operating conditions (Martinez-Coronado, Ruiz-Sanchez, Cerda & Suarez, 2017) Fonseca performs a diagnosis of the technical conditions of the engine using a lubricating analysis, vibration analysis, and thermography (Fonseca, Bezerra, Brito Milk & Birth 2018), A new technique for failure prediction in a plant controlled by computerized SCADA system (Mayadevi, Vinodchandra, & Ushakumari, 2012), A method that detects combustion failures caused by a fuel deficiency in a cylinder, even in its early stages is presented by Nieto (Nieto, Blazquez, Platero, & Marriage, 2017) A cylinder balancing method is disclosed which minimizes the crankshaft torsional vibrations at medium speed internal combustion engines (Ostman & Toivonen, 2008) A systems Supervisory Control and Data Acquisition are designed to allow human operators supervise, maintain and control critical infrastructure (Samtani, Yu, Zhu, Patton, & Chen, 2016), Sanchez and Suarez for fault detection in fossil power plants operation using recurrent neural networks (Sanchez, Suarez, & Ruz, 2004). This paper proposes the specification of a system to collect real-time information of the engine operating cycle dual-fuel, while working with diesel and natural gas, the pressure values of the combustion temperature and pressure of the cooling water in order to identify flaws and preventing the integrity of ICEG's.

II. LITERATURE REVIEW

Internal Combustion Engine (ICE)

An Internal Combustion Engine (ICE) is an artifact que generates mechanical power from the chemical energy, released by burning or oxidizing the fuel inside the engine (Thus the name "internal") There are two main types of engines: Spark Ignited (SI) and Compression Ignited (CI). The first is the engine Which needs a spark to ignite the

fuel inside the combustion chamber (the full cycle is Performed in four strokes or 2 revolutions) while the second Relies on the volatility of fuel under Certain pressure and temperature characteristics That permit the ignition (The full cycle is completed in two strokes or one revolution)). There are many applications where an ICE can be found, and the configuration of the engine is closely related to the specific use. In Fig. 1, is visualized the main components of this engine (Molinar-Monterrubio & Castro-Linares, 2007).

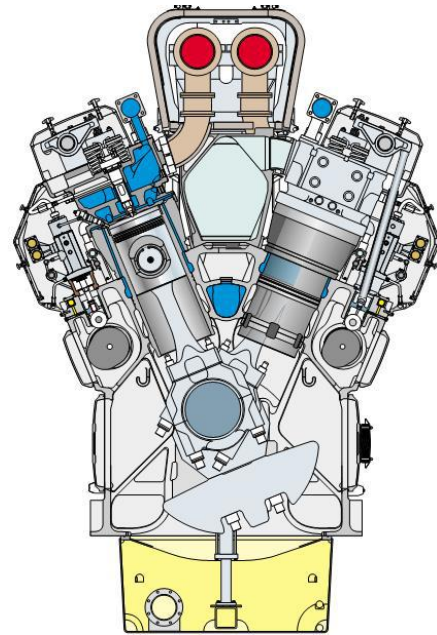

Fig.1: Motor 46 in cross section Wärtsilä® V.

Source:(Wärtsilä, 2015).

In general, the functionality of an ICE can be described in four main phases, Which Can Be Performed in four strokes (two revolutions) or in two strokes (one revolution) cycles (Molinar-Monterrubio & Castro-Linares, 2007):

- Admission, the fuel enters the chamber by means of the mechanical aperture in cylinder together with the aid of the piston draw stroke;
- Compression, the fuel is compressed by the piston stroke up to the top dead center;
- Expansion, the thermic artifice ignites the combustible mixture, which in turn generates mechanical and thermal power;
- Expulsion, the piston stroke pushes out the burned exhaust gas past the mechanical aperture.

Faults in the combustion engine can be identified and Analyzed based on the information collected from the engine environment. Currently, techniques such as engine oil analysis, exhaust gas analysis, analysis engine vibration signal and processed data from various engine sensors are used for fault identification in combustion engines (Liyangedera, Ratnaweera, & Randeniya, 2013).

Industrial instrumentation

The term "instrumentation", according to engineering, is associated with the theoretical and practical study of the instruments and their scientific principles. Are used to monitor continuously, or discrete, the control variables of behavior that, in some way, will interest the man in various areas of human knowledge applied, that is, not only in industrial manufacturing processes (Fialho, 2006). From the point of view of science industrial instrumentation studies, develops and improves techniques for use suitability of measuring instruments, seeking to carry out the collection and transmission of data for the registration and control of physical variables in various equipment allocated in industrial processes.

Measurement Systems

A system is a combination of components that work together and accomplish a certain goal. A system is not limited to something physical. The system concept can be applied to abstract dynamic phenomena such as those found in economics. The word system should therefore be construed to designate physical, biological, economic and other systems (Ogata, 2007). A measurement system is a set of devices (sensors, circuits, cables, displays, equations, computer programs, etc.) whose purpose is to provide information on the value of the physical quantity to be measured, the measuring (Aguirre, 2013).

Measuring Instruments

In general, an instrument can be analyzed in terms of a functional description of its subsystems. Any instrument is usually made up of more than one element. An element or a group of them performs a specific function and a description of the instrument in terms of these functions is called the functional description (Aguirre, 2013). Analyzing some kind of instrument as an entry and exit system. In principle, virtually every physical process can be interpreted as a system with input and output. Following this line, an instrument can be represented as illustrated in Fig. 2, wherein the input is the variable to be measured and the output indication is provided by the instrument. In metrology texts it is common to refer to the input and measuring (Aguirre, 2013).

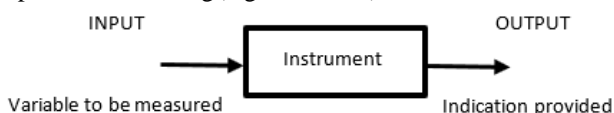

Fig.2: Perfect representation of input and output of an instrument.

Source: adapted from (Aguirre, 2013)

Automation and Control

The control word of French origin (contrôler), denotes the act or power to exercise control, monitor, supervise, maintain balance. Its understanding is ancient and was always the target of achieving common objectives of a

nation, region or community as a whole. Variably found as an asset in the mind of the individual: to control not be controlled (Silveira & Santos, 2004).

Engineering concerns the knowledge and control of materials and forces of nature for the benefit of mankind. Relate to the control system engineers the knowledge and control segments around, often called systems, in order to provide society with useful and affordable products (Dorf & Bishop, 2011).

Automatic control has played a vital role in the advancement of engineering and science. In addition to its extreme importance for space vehicles, for guiding missiles systems, robotic systems and the like, the automatic control has become an important and integral industrial processes and modern manufacturing (Ogata, 2007).

It is the technology that allows the realization of sequential mode of operation, fast and accurate, with little (or no) human intervention. Contrary to what many think, it did not come to "take" jobs, but to generate them (Capelli, 2008).

Sensors

The sensors are the components most used in the world of electronics. They are present in the day-to-day in various situations (cars, elevators, automatic doors, appliances, etc.). These devices are also the entire base of automation, be it industrial, building (domestic) or commercial (Capelli, 2008).

One of the first sensors used in automation were very robust electromechanical and with a good performance. On average, the life of this component is 10 million maneuvers, depending, of course, usage conditions (current and operating voltage and speed). Generally, this sensor provides at least one normally open contact (NA) and a normally closed contact (NC) (Capelli, 2008).

Conduction temperature measurement sensors

All materials consist of particles. These particles are atoms or molecules that are in constant motion. In this constant movement is called as kinetic energy. Thus, the higher the stirring in the particles, the greater the kinetic energy. The zeroth law of thermodynamics: If two bodies A and B are separately in thermal equilibrium with a third body T, A and B are in thermal equilibrium with each other (Halliday, Resnick, & Walker, 2008).

The temperature measurement principle using resistance thermometers based on variation of the value of electrical resistance of a metallic conductor as a function of temperature. Equation (1) is excellent approximation to the variation of electrical resistance versus temperature (Fialho, 2006).

$$R_{(T)} = R_0(1 + \alpha \cdot T) \quad (1)$$

On what:

$R_{(T)}$ - Electrical resistance "T" temperature;

R_0 - Electrical resistance temperature of 0°C ;
 α - coefficient of electrical resistance versus temperature measured in $^\circ\text{C}$;
 T - measured temperature in $^\circ\text{C}$.

As a temperature measuring device consisting of two different conductors which are in contact with each other at one or more points. The thermocouples are widely used as a temperature sensor for measurement and control. Converting into electricity temperature gradient (Fialho, 2006). Fig. 3 is shown the basic assembly of a thermocouple.

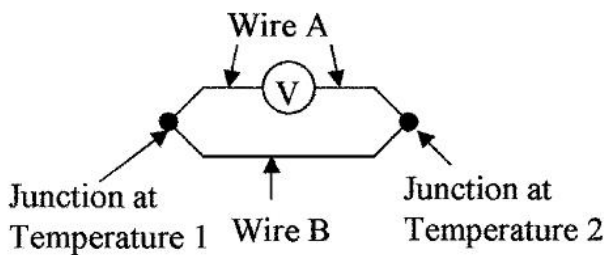

Fig.3: Thermocouple (basic assembly).

Source:(Dunn, 2005).

Strain gages or Gages

These devices whose resistance varies with its deformation. The operating principle of the strain gauges is described mathematically by equation (2), which shows that a resistance element also depends on its geometrical aspects such as length and cross-sectional area. Thus, the strain gauges are resistive elements constructed in a manner to maximize the resistance variation with deformation (Aguirre, 2013).

$$\frac{\partial h}{\partial \rho} \frac{\partial h}{\partial T} \frac{\partial h}{\partial L} \frac{\partial h}{\partial A} \tag{2}$$

Pressure

It can be defined as the pressure measurement orthogonal uniform force exerted by a surface whose area is divided such same strength, which is commonly indicated by the equation (3) (Aguirre, 2013).

$$p = \frac{F}{A} \tag{3}$$

On what:

- F - force [N];
- A - area [m²];
- P - pressure.

Among pressure sensors generally used are the piezoresistive the operation of these sensors is similar to the transducers based on strain gauges membranes, although they are generally smaller and more compact (Aguirre, 2013).

Transducers

Devices running the conversion of a physical quantity in another are called in general TRANSDUCERS (Natale 2001).

The transducers are divided into two categories (Aguirre, 2013):

The first category are passive transducers. Here the energy of the output signal is provided entirely by the input signal generating means or at such signal;

The second category, unlike the former, are the active transducers. In this case, the energy at the transducer output is not from the input signal (at least mostly).

Signal Conditioner

Generally, the output electrical quantity transducer is not directly manipulable. For example, the range of the output voltage is not the desired one, the power of the supplied signal is very small, the type of electrical quantity is not that we need, etc. For all these reasons, the transducer is never presented alone, but accompanied by a SIGNAL CONDITIONER (Natale 2001).

III. MATERIALS AND METHOD

The proposed monitoring system in real time was developed aiming to meet the technical requirements for data acquisition from the sensors accurately and efficiently. Fig. 4 shows a representation of the system simulation and data acquisition.



Fig.4: System simulation and data acquisition.

For the acquisition of temperature data is used the temperature sensor (thermocouple Type K) viewed in Fig. 5.



Fig.5: K-type thermocouple

For acquisition of the air pressure values simulating the pressure of combustion is used VKP Pressure Transmitter-027. IP65, illustrated in Fig. 6.



Fig.6: Pressure Transmitter VKP-027. IP65.

For the acquisition of water pressure values is used Pressure Transmitter Mini VKP-011. IP65, illustrated in Fig. 7, which has the most compact design of the market. Designed to meet industrial applications and meet the challenges of small spaces with precision and efficiency. Its construction is entirely in AISI316L, which makes it compatible with a massive majority of industrial processes.



Fig.7: Pressure Transmitter Mini VKP-011.

In FIG. 8, the prototype machine was installed where the pressure sensors and the cooling water temperature of the combustion system is illustrated.



Fig. 8: Mechanical prototype.

In Fig. 9, illustrated is the combustion pressure of the compressor prototype used to perform the simulation of the combustion pressure variation to the gas inlet into the cylinder. This compressor that injects air chamber to a pressure of 20 bar. This data will be captured by a pressure transducer.



Fig. 9: Prototype combustion pressure.

In fig. 10 is shown the prototype of water pressure with the compressor to simulate enters from the combustion gas within the cylinder of the water chamber in order to simulate the turbulence which can occur due to failure or malfunction of the head gasket .



Fig. 10: Prototype water pressure.

In Fig. 11, is displayed the DAQ assistant, logic block that has the tools for configuring the physical modules of data acquisition and turn it into a digital output that is used to power other blocks to generate graphs of monitored variables.

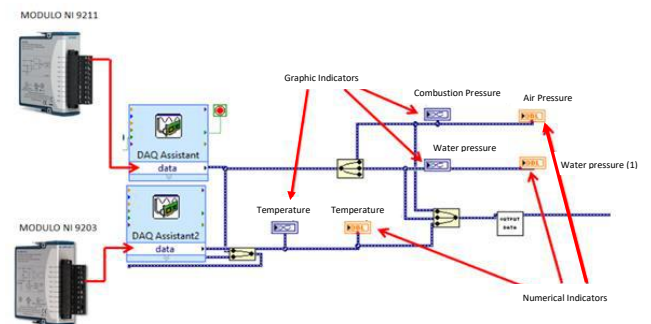

Fig. 11: DAQ assistant.

Fig. 12 illustrates the second part of the logical blocks monitoring the three variables of the proposed monitoring system.

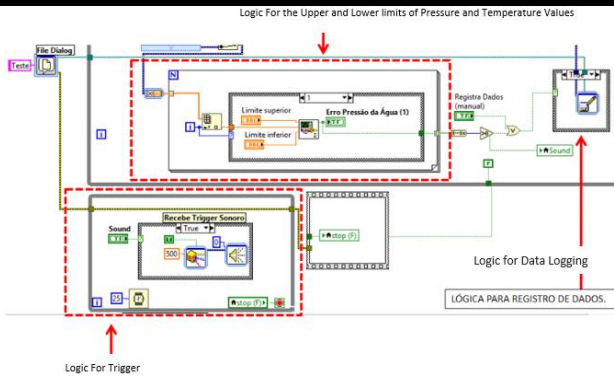

Fig. 12: the second part of the logic blocks.

IV. ANALYSIS OF THE APPLICATION OF THE PROPOSED SYSTEM

Once the sensors are installed and the system started, information is collected through the developed software, the results of a real engine in laboratory scale are simulated. In this case they are tested combustion pressure, temperature and cooling water pressure.

Each test was carried out in stages in order to verify the functionality of the hardware and software and the accuracy of the results.

In Fig. 13, the monitoring screen is displayed combustion pressure.

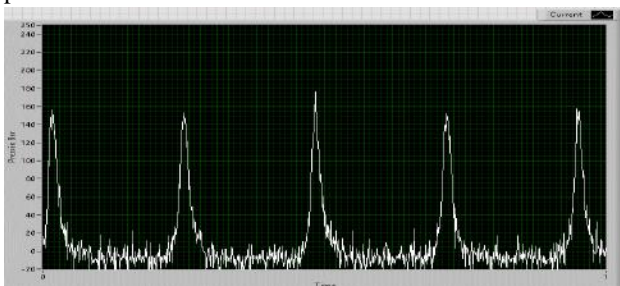

Fig. 13: Graph Combustion pressure.

The values shown are within specifications for engine combustion system.

In Fig. 14, is displayed on the monitoring screen cooling water pressure.

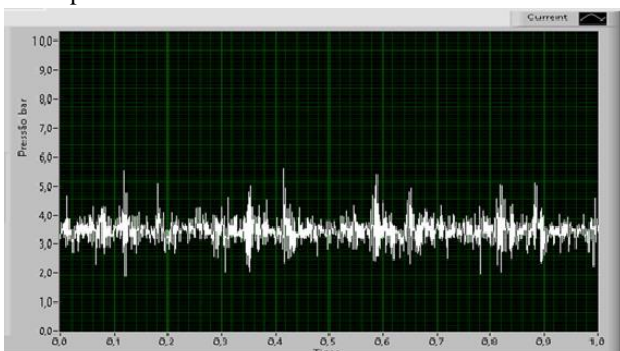

Fig. 14: Graph of water pressure.

The figures are within the specifications for the engine water pressure system.

In Fig. 15, is displayed on the monitoring screen cooling water temperature.

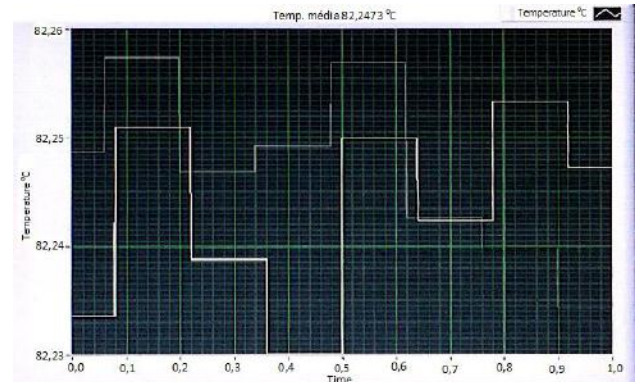

Fig. 15: Graph water temperature.

The values obtained are within the specifications for the engine cooling water temperature of the system.

V. CONCLUSION

The prototype proposed for the monitoring system of the generator operating parameters from the values collected from the combustion pressure and temperature variables and engine cooling water pressure provides data for diagnosis and fault detection in the power generation process this engine. The use of sensors for real-time data capture, proved to be streamlined and efficient, providing parameters for fault detection in the engine operating conditions, enabling greater reliability and safety in power generation. Monitoring these variables proved to be indispensable to preserve the proper functioning of these machines TPP.

ACKNOWLEDGMENTS

To the Institute of Technology and Education Galileo of the Amazon (ITEGAM), Postgraduate Program in Process Engineering (PPGEP) of the Federal University of Pará (UFPA), Generator of Energy of Amazonas S/A, Generator of Energy of Maranhao S/A, Foundation of Support to the Research of the State of Amazonas (FAPEAM) and National Electric Energy Agency (ANEEL R&D PD-06492-0117/2017) by supporting research.

REFERENCES

- [1] Aguirre, L. A. (2013). Fundamentos de instrumentação. Luis Antonio Aguirre.
- [2] Cabeza, R. T., Santiago, O. L., Vicedo, E. B., & Vega, V. M. (2018). Faults Diagnostic using Hopfield Artificial Neural Network in front of Incomplete Data. *Journal of Engineering and Technology for Industrial Applications - JETIA*,

- 4(13), 6. doi: <https://dx.doi.org/10.5935/2447-0228.20180011>
- [3] Capelli, A. (2008). *Automação industrial: controle do movimento e processos contínuos*: Ed. Érica.
- [4] Coronado-Martinez, F. U., Ruiz-Sanchez, F. J., & Suarez-Cerda, D. A. (2017, 8-10 Nov. 2017). *Fault detection and diagnosis of complex engineering systems based on a NNARX multi model applied to a fossil fuel electric power plant*. Paper presented at the 2017 IEEE International Autumn Meeting on Power, Electronics and Computing (ROPEC).
- [5] Dorf, R. C., & Bishop, R. H. (2011). *Modern control systems*: Pearson.
- [6] Dunn, W. C. (2005). *Fundamentals of industrial instrumentation and process control* (Vol. 681): McGraw-Hill.
- [7] EPE, E. d. P. E. (2017). BRAZILIAN ENERGY BALANCE. *Empresa de Pesquisa Energética. – Rio de Janeiro*.
- [8] Fialho, A. B. (2006). *Instrumentação industrial: conceitos, aplicações e análises*: Editora Érica.
- [9] Fonseca, M., Bezerra, U. H., Brito, J. d. A., Leite, J. C., & Nascimento, M. H. R. (2018). Pre-dispatch of Load in Thermoelectric Power Plants Considering Maintenance Management using Fuzzy Logic. *IEEE Access*, 1-1. doi:10.1109/ACCESS.2018.2854612
- [10] Halliday, D., Resnick, R., & Walker, J. (2008). *Fundamentos de Física*, 8a. edição, Vol. 2, LTC: Wiley.
- [11] Lima, M. T. d. S. L., & Souza, M. C. d. (2014). Considering on the Use of Thermal Power Plants in Brazil. *Ciência e Natura*, 37(Especial UFVJM), 7. doi:10.5902/2179460X18493
- [12] Liyanagedera, N. D., Ratnaweera, A., & Randeniya, D. I. B. (2013, 17-20 Dec. 2013). *Vibration signal analysis for fault detection of combustion engine using neural network*. Paper presented at the 2013 IEEE 8th International Conference on Industrial and Information Systems.
- [13] Mayadevi, N., Vinodchandra, S. S., & Ushakumari, S. (2012, 23-25 Aug. 2012). *Failure forecast engine for power plant expert system shell*. Paper presented at the 2012 IEEE International Conference on Advanced Communication Control and Computing Technologies (ICACCCT).
- [14] Mendonça, P., Bonaldi, E. L., de Oliveira, L. E. d. L., Torres, G. L., da Silva, J. G. B., da Silva, L. E. B., . . . Santana, W. C. (2007). Desenvolvimento de Sistema Preditivo para Diagnóstico Termomecânico de Falhas em Motores de Combustão Interna.
- [15] MME. (2016). *Resenha Energética Brasileira 2016. MME: Ministério de Minas e Energia. Resenha Energética Brasileira 2016 . Disponível em: <<http://www.mme.gov.br/programas/proinfa/>> Acesso em: 4 nov. 2017., 12(45-67).*
- [16] Molinar-Monterrubio, J., & Castro-Linares, R. (2007, 25-28 Sept. 2007). *Sliding Mode Observer for Internal Combustion Engine Misfire Detection*. Paper presented at the Electronics, Robotics and Automotive Mechanics Conference (CERMA 2007).
- [17] Natale, F. (2001). *Automação Industrial. 2ª edição Revisada e Atualizada*.
- [18] Nieto, F. J., Blazquez, F., Platero, C. A., & Casado, A. J. (2017, Aug. 29 2017-Sept. 1 2017). *Combustion problem identification based on electric power output oscillation assessment for Diesel-Engine driven generators*. Paper presented at the 2017 IEEE 11th International Symposium on Diagnostics for Electrical Machines, Power Electronics and Drives (SDEMPED).
- [19] Ogata, K. (2007). *Modern control engineering* (Vol. 4): Prentice hall India.
- [20] Ostman, F., & Toivonen, H. T. (2008). Model-based torsional vibration control of internal combustion engines. *IET Control Theory & Applications*, 2(11), 1024-1032. doi:10.1049/iet-cta:20070479
- [21] Samtani, S., Yu, S., Zhu, H., Patton, M., & Chen, H. (2016, 28-30 Sept. 2016). *Identifying SCADA vulnerabilities using passive and active vulnerability assessment techniques*. Paper presented at the 2016 IEEE Conference on Intelligence and Security Informatics (ISI).
- [22] Sanchez, E. N., Suarez, D. A., & Ruz, J. A. (2004, June 28 2004-July 1 2004). *Fault detection in fossil electric power plant via neural networks*. Paper presented at the Proceedings World Automation Congress, 2004.
- [23] Silveira, P. R. d., & Santos, W. E. d. (2004). *Automação e controle discreto*: Érica.
- [24] Trindade, G. H., Sperling, E., & Bourbon, F. d. (2017). *Geração de Energia Elétrica no Brasil. ANEEL - Agência Nacional de Energia Elétrica*.
- [25] Wärtsilä. (2015). *Instruction Manual - WÄRTSILÄ 18V 46. Wärtsilä Finland Oy, 486*.